



PRODUCT CARE GUIDE

robertson[®]
 BATHWARE
 — SINCE 1987 —

ROBERTSON.CO.NZ

Thank you for purchasing our product. This flyer will assist you in keeping the product looking like new for years to come. Included is handy information, tips and hints for cleaning, removing and tightening components.

Warranty and spare parts information can be found on the back page.

Please note information provided should be read in conjunction with manufacturers instructions supplied with the product.

→ **FLAMINIA.**

ZUCCHETTI. KOS

SAMUEL HEATH
since 1820

HIDRA
 CERAMICA

ELEMENTI

COTTO



victoria ⊕ albert[®]

NOBILIT

the.artceram

apaiser

PARISI

alice

AQUAECO

OLI

PRODUCT CARE

To be read in conjunction with manufacturers instructions supplied with the product.



BATHS

Quarrycast Baths

Repairing a scratch:

- If any scratches occur during installation these can be removed by rubbing with a 1500+ grit waterproof abrasive paper and water.
- Re-polish the surface afterwards using a neutral automotive colour restorer or household metal polish.
- It may be possible to polish very fine scratches away without using abrasive papers: scrubbing gently with a soft brush or plastic pad (not metal scouring pad) and a mildly abrasive cream cleaner. Afterwards scrub the whole area with plenty of clean water and re-polish as before.

Everyday Cleaning:

- We recommend a non-abrasive bathroom or kitchen household cleaner. Abrasives will cause the disappearance of the glossy look over a long period. Should you need to clean the bath with an abrasive cleaner, as may be required from time to time, polishing with a car polish or household metal polish will restore the baths lustre.

Acrylic Baths

- Clean regularly to stop build up of dirt and scale using warm, soapy water.
- Occasional use of mild bathroom limescale removers is acceptable. Use in accordance with manufacturers instructions, rinsing off immediately with plenty of water.
- Minor scratches and abrasions can be polished out with a mild polishing compound.
- Never let cigarettes/flames near.
- Never use household chemicals – a range of products such as paint stripper, nail varnish remover, household bleach, perfume, aftershave or strong disinfectant can damage acrylic products.
- We cannot recommend the use of any scouring products or cream cleaners as acrylic is softer than china and can scratch

Matt Finishes

- People tend to think that matt finished sanitary ware requires special care or specified products, but in actual fact the procedure to be followed for matt ceramic is the same as for glossy ceramic. The widespread use of matt ceramic has raised many questions on how to clean it, while in actual fact the parts that need extra care when cleaning the toilet bowl, the bidet, the washbasin and the bathtub are the chromed parts. The same maintenance and cleaning rules apply irrespective of the finish – white or coloured, matt or glossy – of the ceramic surface.

Apaiser Marble

After Installation

- The core properties of apaiser marble mean that the product is inert and non-porous. After installation of your product, if required, wash the item with a cream based cleanser, and wet microfibre cloth. This will remove any marks left behind during installation and delivery.

Daily Cleaning

- For daily cleaning apaiser recommends a microfiber cloth and water, be sure to rinse and dry your product fully after cleaning. If a stain or substance is left on the surface, such as makeup, essential oils or just simple soap and bath oils, again use a cream cleanser and wet cloth. Be sure to rinse well, and fully dry your product after cleaning. **IMPORTANT :** The properties of the material mean these cleaners will not damage the surface of the bathware, however products containing Sulfamic acid will cause damage and use of these will void manufactures warranty.

Repairs

- Your apaiser product has a high concentration of reclaimed marble and pure Australian minerals, this, combined with our hand crafted build technique allows for perfect on site repairs to scratches and minor chips. Your apaiser product can be sanded back with fine graded wet n dry sandpaper to remove scratches and restore a beautiful finish, and colour matched repair kits are available in the unlikely event that your item is chipped.

Apaiser service is available to assist with any queries you may have, you can contact service@apaier.com for more information on service and repairs.

StoneTec

After Installation

- To maintain the appearance of Stonetec, use a cloth that has been rinsed in warm soapy water, and dry with a clean, dry cloth. For stubborn marks or stains use a mild multi-purpose paste cleaner in a firm circular motion, always finish by wiping the surface with a damp soft sponge and wipe dry. Do not use abrasive cleaners as it will dull the finish.



SHOWER ENCLOSURES

Shower Trays and Wall Liners

- Regular cleaning is required to stop build up of dirt and soap scum.
- When cleaning acrylic surfaces always use non abrasive cleaners then rise off with water. (Cleaners with peroxide and ammonia can be very harmful to acrylics)
- We recommend drying the surfaces after cleaning to prevent further build up of soap and grime.

Glass

- Whilst our award winning Nano glass technology has a non stick surface it still requires maintenance cleaning to stop the build up of grime, soaps and water staining.
- Glass will stain by allowing water to remain on the surface. This can be prevented by regular cleaning with glass cleaner or warm soapy water along with rinsing off and then drying of the glass panels.

Any shower Cleaner product that states to spray and leave on for a period of time can compromise the acrylic and cause shrinkage and superficial cracking and is not recommended.

PRODUCT CARE



TAPWARE & MIXERS

- Clean with warm soapy water using a soft cloth. Do not use steel wool or pads.
- Do not use any cleaning agents containing acids (including citrus), polish abrasives, or harsh cleaners. Regular and routine cleaning and polishing will reduce the need for heavy cleaning and polishing.
- Once cleaned, rinse again with clear water and blot dry with a soft cotton cloth.
- The use of steam cleaners is not recommended since the extreme high temperature of steam can compromise the integrity of the coating finish.

HARDWATER (LIMESCALE / CALCIUM)

- Make a solution of equal quantities of white vinegar and warm water. Dip a cloth into the mixture and use it to clean up your taps. In case of a stubborn buildup of limescale, you can wrap a cloth dipped in the vinegar solution and leave it for an hour before washing it clean. Following this, rinse and dry the fixture as vinegar is mildly acidic and can damage the finish if left on.
- With a ring around a basin / bath waste on vitreous China Brass Brite can be used and polished off with a non abrasive pad.
- Be extra careful with coloured tapware or concrete products as some colour can be a painted finish (tapware) or pigmented colour (concrete products) and will require extra care.
- NB: the only permanent fix for hard water (mineral build up) is to install a water softening device that filters the water for the entire home.
- A Water Softener is a filtration system that works to remove high concentrations of calcium and magnesium that cause hard water. When water flows through a Water Softener, the system filters out these hard water minerals and the softened water then leaves the water softening system to flow through plumbing.
- You can discuss water softener devices with a technician at Robertson Trade



TOILETS

- The seat and cover should be cleaned using warm soapy water.
- Do not use aggressive or abrasive cleaners as this may scratch the surface of the seat.
- The hinges should be cleaned using soap, or a mild detergent. After cleaning the hinges should be rinsed in clean water and dried.
- Never use bleach, concentrated cleaners or acids on the hinges as this will cause discolouring and pitting.
- Do not leave bleach in the toilet bowl with the cover closed because this may cause discolouration of the seat and hinges.
- Take care not to splash the hinges when using bleach in the toilet bowl.
- Do not bleach products in the cistern - this can damage the internal fittings. However, it is acceptable to use in the toilet bowl itself.
- Never put strong cleaners or bleach in overnight.
- Never mix different cleaners in the WC - they can react and give off poisonous gas.

Soft Close Seats

- With any soft close seat it is imperative that the seat is not force closed this will put undue pressure on the soft close mechanism and can lead to failure of the mechanism.
- Do not let the seat become loose periodical maintenance is required, seat hinges should be checked and tightened every 3 - 6 months, the seat needs to be soundly attached to the pan as this can lead to hinge damage and soft close mechanism issues as the soft close will not correctly operate unless the seat is firmly attached to the pan.
- If the hinge becomes very loose it is also important to clean and dry the pan where the hinge seals to the pan otherwise the hinge will work its way loose very quickly.

Matt Finishes

- People tend to think that matt finished sanitary ware requires special care or specified products, but in actual fact the procedure to be followed for matt ceramic is the same as for glossy ceramic. The widespread use of matt ceramic has raised many questions on how to clean it, while in actual fact the parts that need extra care when cleaning the toilet bowl, the bidet, the washbasin and the bathtub are the chromed parts. The same maintenance and cleaning rules apply irrespective of the finish - white or coloured, matt or glossy - of the ceramic surface.



ACCESSORIES

To maintain your Elementi accessories and keep their brand new lustre, follow these simple instructions:

- Clean with warm soapy water using a soft cloth. Do not use steel wool or pads.
- Do not use any cleaning agents containing acids (including citrus), polish abrasives, or harsh cleaners. Regular and routine cleaning and polishing will reduce the need for heavy cleaning and polishing.
- Once cleaned, rinse again with clear water and blot dry with a soft cotton cloth.
- The use of steam cleaners is not recommended since the extreme high temperature of steam can compromise the integrity of the coating finish.
- Do not spray cleaning agents directly on the accessories. Spray on the cloth as spray liquid may enter into openings/holes and cause damage.

Mirrors

- To keep mirrors from 'black spotting' regularly oil any exposed edges. Do not use any acid or alkaline based cleaners. A micro-fibre cloth will give you the best results.

Concrete

- Light duties for the first 7 days to allow sealer to cure. After 7 days the basins are safe to use and after 28 days are scratch resistant.
- Do not place any objects in the basin for the first 7 days.
- Wipe as you go, using a damp soft cloth (microfiber cloths are ideal).
- If you encounter stubborn stains, use a mild non-abrasive cleanser.
- Avoid exposure to products with high ph levels such as specialised cleaners. If exposure occurs rinse immediately with water to neutralize effect and then follow usual cleansing procedure.
- Do not leave moist or wet products directly on concrete for a prolonged period.

PRODUCT CARE



FURNITURE

Wood Veneer and Paint Surfaces

- Non abrasive cleaning products can be used for stubborn marks.
- Do not use abrasive cleaning products or silicone based products.

Multi-Wood Laminate Timber

- For all surfaces use only a soft cloth and a weak solution of non-abrasive cleaner.

Melamine

- Bestwood Melamine is low maintenance and easy to clean. For regular cleaning, simply wipe with a clean, damp cloth. Stubborn grease and grime can be cleaned using diluted vinegar and water or sugar soap.
- Stains should be tackled early with hot, soapy water, or use some of the techniques below. Always wipe with a damp cloth, then a dry cloth after cleaning to remove moisture.
Food spills: All purpose surface cleaner
Shoe Polish: Diluted vinegar or lemon juice
Paint/glue: Wipe with acetone to loosen, then wipe clean with warm, soapy water and wipe dry
Hair/leather dye: Wipe with methylated spirits, then a clean, damp cloth
Pencil: Clean with a cloth and water
Stubborn marks/stains: Clean with Ajax Spray & Wipe and a soft nylon nail brush to remove dirt particles.
- NEVER use abrasive cleaners or cleaning tools on Bestwood Melamine. Do not use Jif, Vim, Brasso, Mr Muscle cleaner, wire wool or sandpaper

Thermoform

- Thermoform vinyl is a highly durable surface that is easy to look after.
- Your Thermoform doors may have a protective peel coat and this is generally removed at the time of installation - no special cleaning is required when this is removed.

Everyday Cleaning

- Wipe down with a clean damp cloth. Wipe dry to remove moisture.

For Spills, Splashes, Greasy Marks & General Grime

- Wipe down with warm water and detergent or a general-purpose spray and wipe cleaner, then rinse by wiping down with a clean damp cloth. Wipe dry to remove moisture.

Note:

- Don't use steam cleaners on or around your Thermoform doors/drawers as this could allow moisture to permeate around the edge and lead to delamination of the thermoform vinyl.

EleStone

- Routine Cleaning:
The non-porous and hygienic properties of EleStone, do not allow food, dirt, bacteria and germs to penetrate the surface. Routine cleaning with soap, water and a sponge, or window cleaner and paper towels will remove most dirt and stains. For general stains, removal procedures will depend on the finish of the surface.
- Stains:
For general stains, removal procedures will depend on the finish of the surface. Use a microfibre cloth with diluted bleach or diluted dishwashing liquid. Lightly rub in a circular motion. Rinse and towel dry.
- Stubborn Stains:
Diluted Jif (or similar cream cleanser) 20:80 water. Use a microfibre cloth and wipe the entire vanity top, lightly rubbing in a circular motion. Please contact EleStone for more information.
- Disinfecting Surfaces:
Wipe the EleStone vanity top with diluted household bleach (1:1 water/bleach solution) to disinfect.
- Preventing Damage:
Your EleStone Vanity Top can be repaired, however, use the following guidelines to prevent damage to the EleStone surface.
 - Hot Objects:
Protect your EleStone Vanity Top from hot objects, like hair straighteners with a hot pad or trivet with rubber feet.
 - Chemical Protection:
Some strong chemicals can cause damage to your EleStone Vanity Top if left in contact for too long. Products such as: paint remover, solvent containing methylene chloride or acetone (nail polish remover), acid drain cleaner, toilet bowl cleaner, contact adhesive, solvent, rust remover, or lacquer thinners can cause damage to the EleStone surface. If these products do come into contact, the surface should be immediately flushed with soapy water, rinsed with clean water then towel dried.
 - Sharp or Rough Objects:
Sharp or rough objects such as decorative items, scissors or needles can damage your EleStone Vanity Top. Always protect the surface from rough or sharp objects.

Concrete

- Refer to Basins.

Mirrors

- To keep mirrors from 'black spotting' regularly oil any exposed edges. Do not use any acid or alkaline based cleaners. A microfibre cloth will give you the best results.

Natural Stone and Marble

- Marble counter-tops can give a sleek, elegant look to any kitchen or bathroom. But while it is a durable material, cleaning it can be difficult if you don't use the right products. To keep your marble counter clean and protected, sealing it regularly is key so it's not as easy for stains to penetrate the stone.
- With a counter-top that's already been sealed, you should strip off the old sealer before applying a new coat. Wet a clean cloth with an Acetone cleaning solvent and smooth it over the marble. Next, dampen another clean cloth with warm water to remove any residue. Dry the counter with a microfibre cloth. Don't allow the counter-top to air dry; wipe it down to dry it.
- Always apply the sealer exactly as directed to on its packaging. Some sealers may require alternative application methods. After you've allowed the sealer to soak in for the proper amount of time, you must remove any excess product that hasn't absorbed. Use a clean dry cloth to wipe it away.
- To keep your counter-top stain free, you should reseal the marble every three to six months.
- To clean and protect the stone or marble surface, first remove dust using a soft dry cloth (microfibre or lint-free). Use a soft damp cloth and a water-based cleaner, PHneutral stone cleaner or a mild soap diluted in warm water, and thoroughly wipe down the entire marble counter-top. Marble is prone to water spots so always dry immediately when wet.
- Marble is a natural stone and must be cleaned with care. Do not use anything abrasive (such as steel wool or scourers) or acidic (vinegar, window cleaner, bleach or ammonia) as these can damage the marble.



SHOWERS

- Clean with warm soapy water using a soft cloth. Do not use steel wool or pads.
- Do not use any cleaning agents containing acids (including citrus), polish abrasives, or harsh cleaners. Regular and routine cleaning and polishing will reduce the need for heavy cleaning and polishing.
- Once cleaned, rinse again with clear water and blot dry with a soft cotton cloth.
- The use of steam cleaners is not recommended since the extreme high temperature of steam can compromise the integrity of the coating finish.

HARDWATER (LIMESCALE / CALCIUM)

- Limescale, a hard, chalky deposit of calcium carbonate can accumulate on shower over head showers and handpieces, these deposits can block the soft water outlet nipples and accumulate within the handpieces function button.
- If you are in a hardwater area, you may need to carry out regular maintenance on these shower components;
 1. Overhead showers are easily removed and checked, if the outlet silicone nipples are blocked you can simply rub them with your palm this will dislodge any calcium build up, the same goes with your handpiece.
 2. To clean the function mechanism of the handpiece a solution of vinegar / water (50/50) can be used to soak the handpiece for 15 - 30 minutes, or a solution called CLR Calcium, Lime and Rust remover (available from your local hardware) can also be used, please use only as directed on the label.
- NB: the only permanent fix for hard water (mineral build up) is to install a water softening device that filters the water for the entire home.
- A Water Softener is a filtration system that works to remove high concentrations of calcium and magnesium that cause hard water. When water flows through a Water Softener, the system filters out these hard water minerals and the softened water then leaves the water softening system to flow through plumbing.
- You can discuss water softener devices with a technician at Robertson Trade



BASINS

Vitreous China

- Clean the vitreous china immediately after use to stop a build up of dirt and scale using warm soapy water, cream or liquid cleaner.
- Ensure that any dripping taps are fixed - this will prevent stains and limescale build up.
- Occasional use of mild bathroom limescale removers is acceptable. Use in accordance with manufacturers instructions, rinsing off immediately with plenty of water.
- Never put strong cleaners or bleach in overnight.

Concrete

- Light duties for the first 7 days to allow sealer to cure. After 7 days the basins are safe to use and after 28 days are scratch resistant.
- Do not place any objects in the basin for the first 7 days.
- Wipe as you go, using a damp soft cloth (microfiber cloths are ideal).
- If you encounter stubborn stains, use a mild non-abrasive cleanser.
- Avoid exposure to products with high pH levels such as specialised cleaners. If exposure occurs rinse immediately with water to neutralize effect and then follow usual cleansing procedure.
- Do not leave moist or wet products directly on concrete for a prolonged period.

Matt Finishes

- People tend to think that matt finished sanitary ware requires special care or specified products, but in actual fact the procedure to be followed for matt ceramic is the same as for glossy ceramic. The widespread use of matt ceramic has raised many questions on how to clean it, while in actual fact the parts that need extra care when cleaning the toilet bowl, the bidet, the washbasin and the bathtub are the chromed parts. The same maintenance and cleaning rules apply irrespective of the finish - white or coloured, matt or glossy - of the ceramic surface.

HARDWATER (LIMESCALE / CALCIUM)

- Make a solution of equal quantities of white vinegar and warm water. Dip a cloth into the mixture and use it to clean up your taps. In case of a stubborn buildup of limescale, you can wrap a cloth dipped in the vinegar solution and leave it for an hour before washing it clean. Following this, rinse and dry the fixture as vinegar is mildly acidic and can damage the finish if left on.
- With a ring around a basin / bath waste on vitreous China Brass Brite can be used and polished off with a non abrasive pad.
- Be extra careful with coloured tapware or concrete products as some colour can be a painted finish (tapware) or pigmented colour (concrete products) and will require extra care.
- NB: the only permanent fix for hard water (mineral build up) is to install a water softening device that filters the water for the entire home.
- A Water Softener is a filtration system that works to remove high concentrations of calcium and magnesium that cause hard water. When water flows through a Water Softener, the system filters out these hard water minerals and the softened water then leaves the water softening system to flow through plumbing.
- You can discuss water softener devices with a technician at Robertson Trade

THE USE OF CHEMICAL CLEANERS

For all Robertson products it is imperative that you only clean with non-aggressive cleaning products and wash off any residue, if your product has a care guide as part of the instructions of use it is important to follow those cleaning instructions, if you are unsure that your household cleaner is appropriate, please contact the After Sales Service Team for advice.

The use of any cleaning products that are not in the instruction care guide or approved by Robertson could void your products warranty.

PRODUCT HINTS AND TIPS

TOILET SEAT REMOVAL

Double Release Lid



There is a button on each side of the lid. Press to release and remove the lid.

Pull & Release Lid



To Release a lid with no release buttons, simply open the toilet lid, quickly and firmly pull up as shown

Single Button Release



To Release a lid with a single button just open the lid and press the button to release.

TIGHTENING TOILET SEAT



Detach (as shown in toilet seat removal above)

Remove Cover

Tighten

PRODUCT HINTS AND TIPS

REMOVE TOILET LID



Push one button down



Pull out other button



Pull out second button



Undo screw

NOTE: Reverse the above process to replace

ACCESSORIES



Typical fitting



Grub screw at base



Tighten or remove using Allen Key

TAP HANDLE REMOVAL



Remove indicator



Use Allen Key to tighten or undo

VANITY SOFT CLOSE MECHANISM FAILURE



If you have a situation where the soft close mechanism fails to operate correctly, the following are possible causes to be considered:

A drawer not being located correctly. This would be evident from the installation, or if the drawer has been removed and re-fitted, remove the drawer and refit making sure it is fully engaged in the runner.

Check that the runner does not contain saw dust or debris added during the install and has not been cleaned out.

Check that there is nothing jammed in the spring area of the runner, that is the part that pulls it shut.

Very rarely, the synchronisation of the two runner beams comes apart, this will require new runners.

If the drawer has been heavily filled, this can break the motion break motion, in this instance the drawer will just close very fast and then potentially can fail over time.

Note: the soft close mechanisms in our drawers are tested to 60,000 cycles, so runner failure is very rarely the reason why a drawer will not close successfully.



VANITY DRAWER ADJUSTMENT

HETTICH

MEDIAN, APEX AND SUMMIT. With extended use of your cabinetry, adjustments may sometimes be required. Superior Cabinets hinges are simple to adjust.

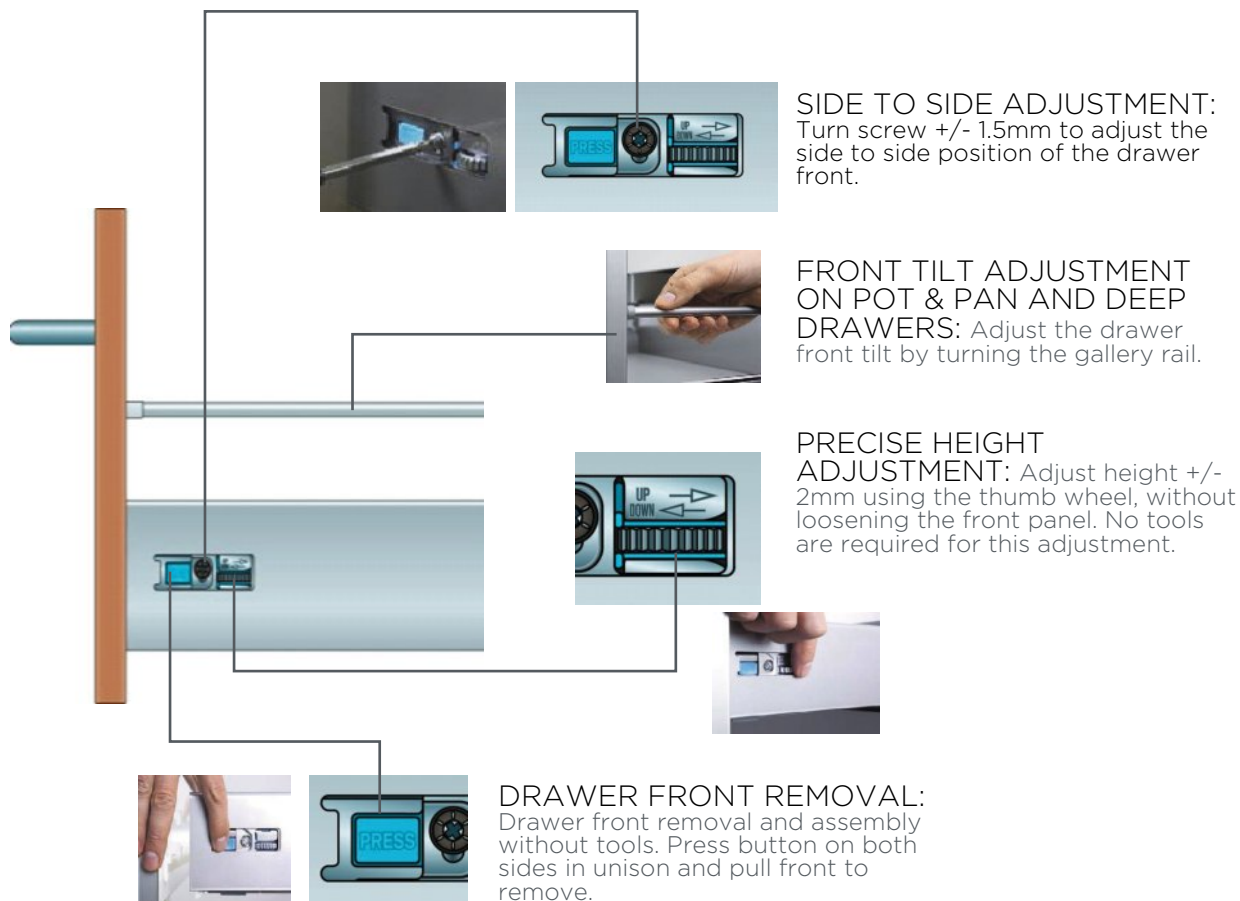

DRAWER INSTALLATION AND REMOVAL:

The drawer is fitted simply by pulling out drawer runners, positioning drawer on the runners and pushing it into place. It is automatically connected to the runner by two catches. You will here a click when it has engaged. Removal is just as easy. The catches on the bottom of the drawer box are pressed in while pulling the drawer forward.

VANITY DRAWER ADJUSTMENT

TITUS

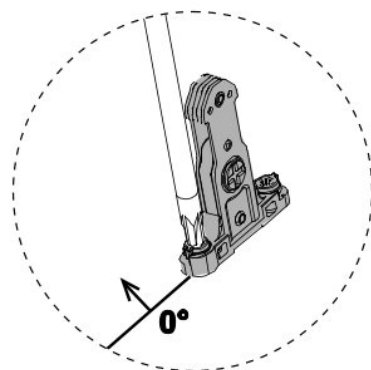
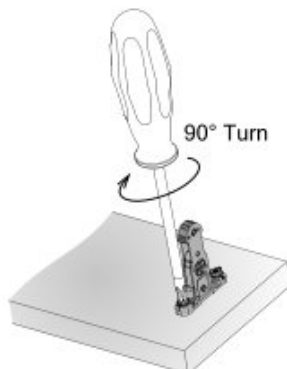
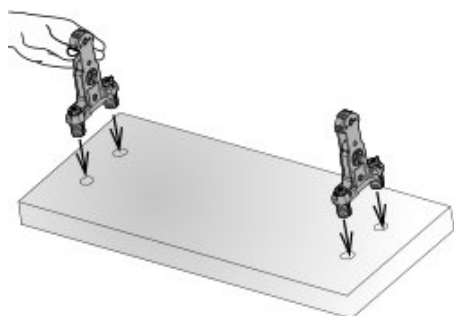

Insertion of Front Connectors

A. Easy Fix

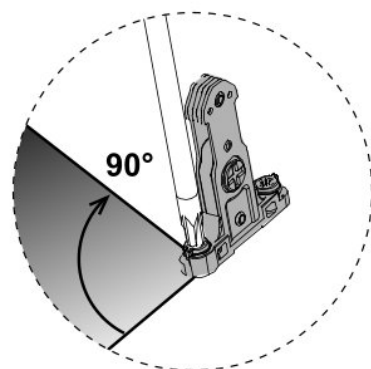
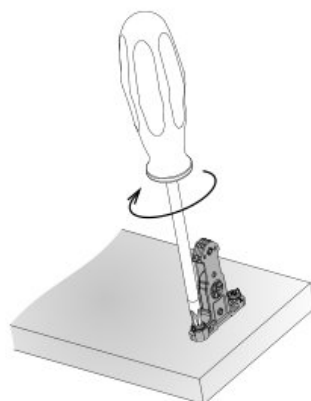
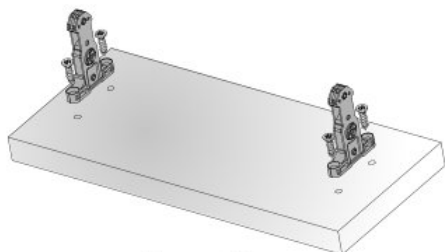

B. Screw in Fixing



Ø3.5 x 15 mm  

TITUS

Front Panel Mounting

Attach the front panel to the drawer.

Press to click

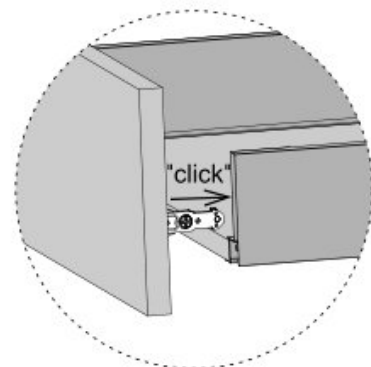
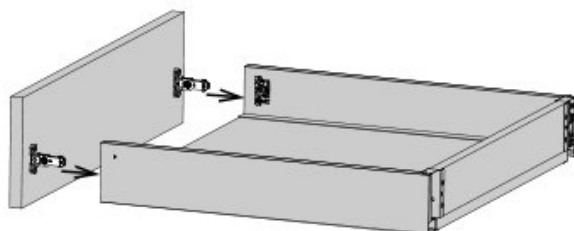

Removal

Rotate towards the front panel to disengage

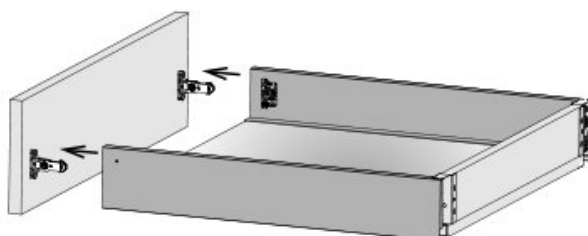
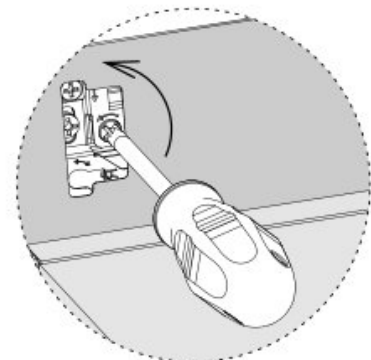
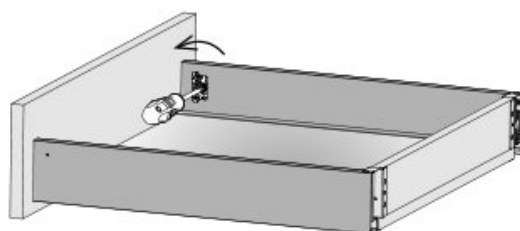

VANITY DRAWER ADJUSTMENT

TITUS

Side Adjustment

To align the drawer front with the cabinet side rotate the adjustment screw.

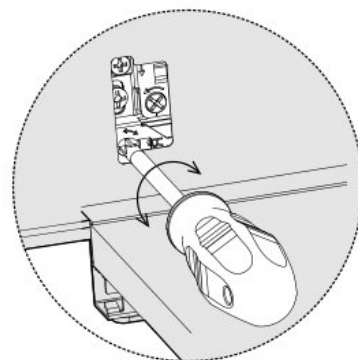
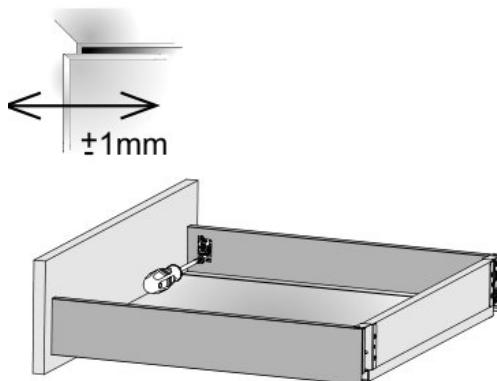

Height Adjustment

Release the locking screw.

Rotate the eccentric dowel and tighten the locking screw

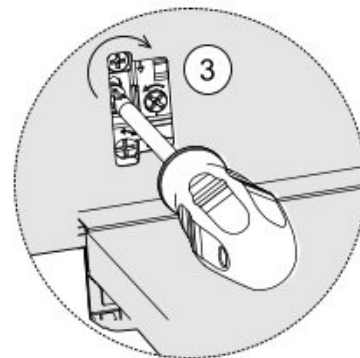
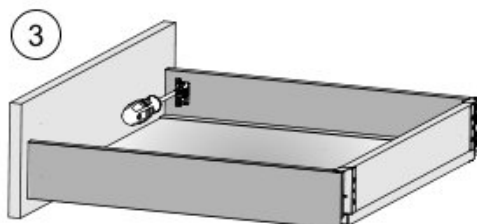
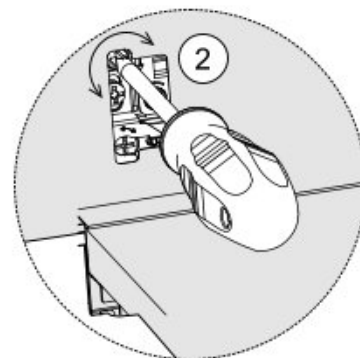
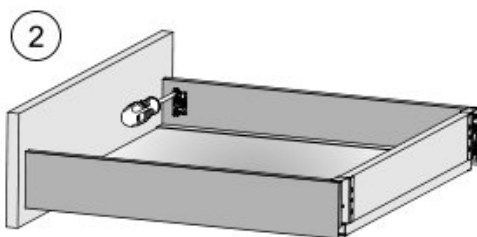
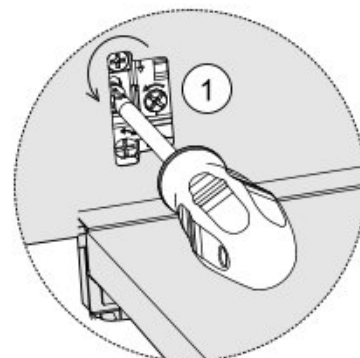
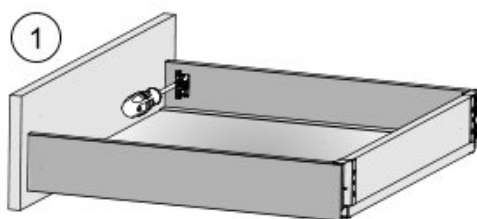
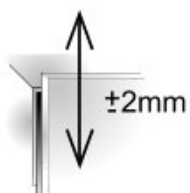

VANITY DRAWER ADJUSTMENT

HAFELE

Drawer front installation and removal

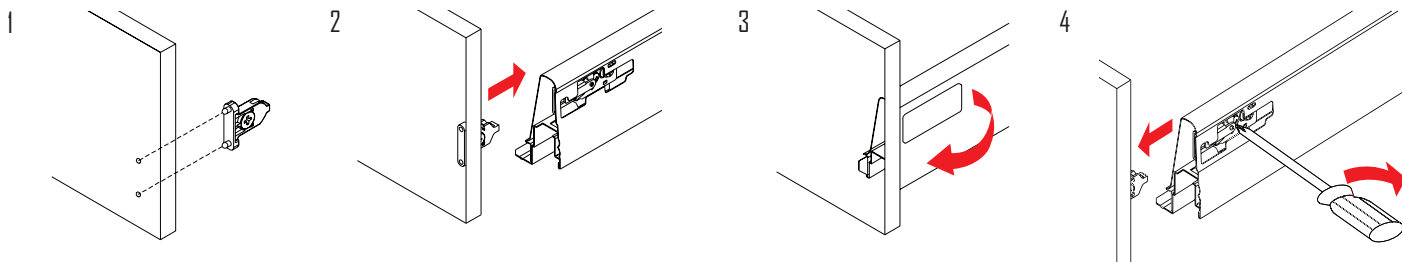

Adjustment

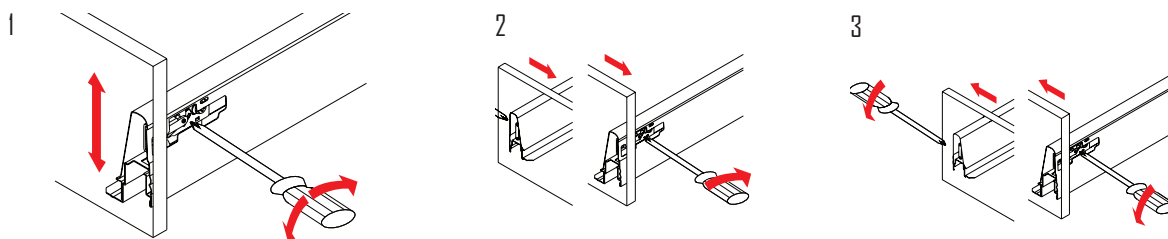

Drawer Insertion & Removal

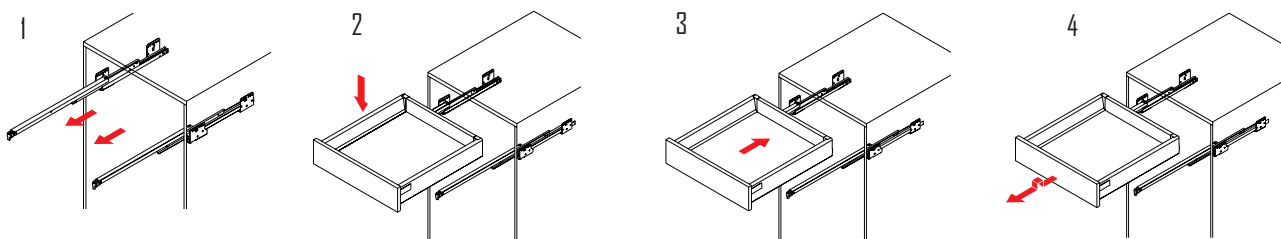

VANITY DRAWER ADJUSTMENT

BLUM

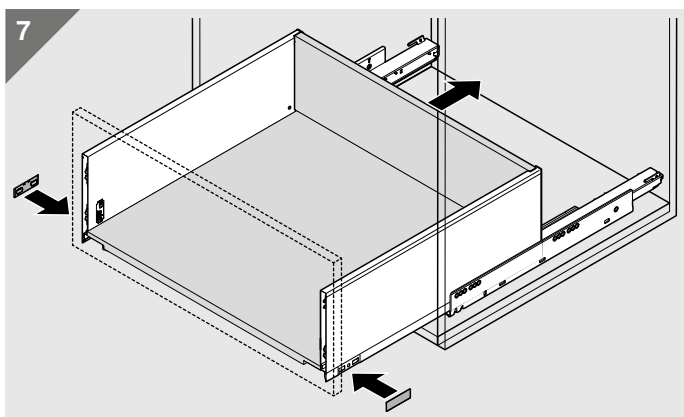
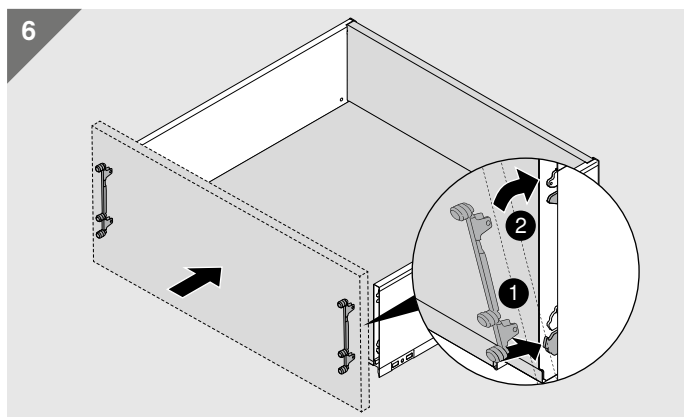
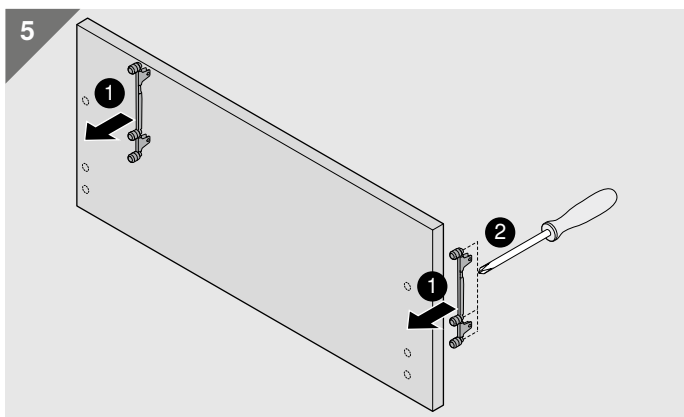
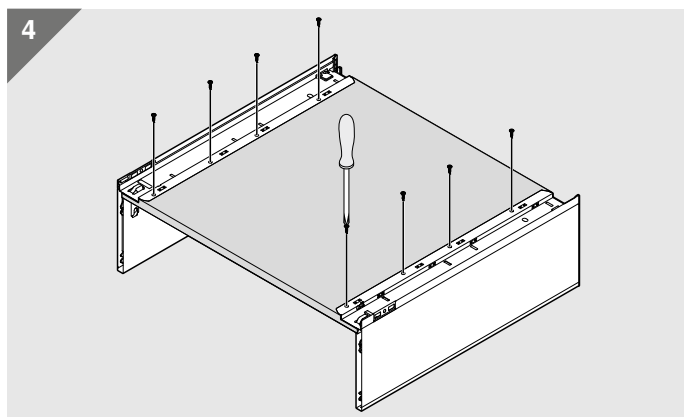
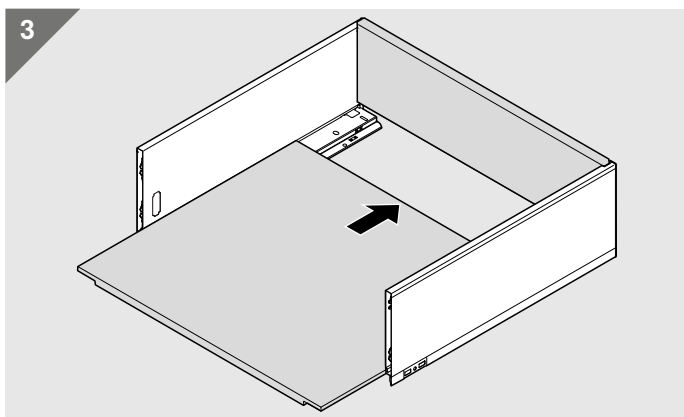
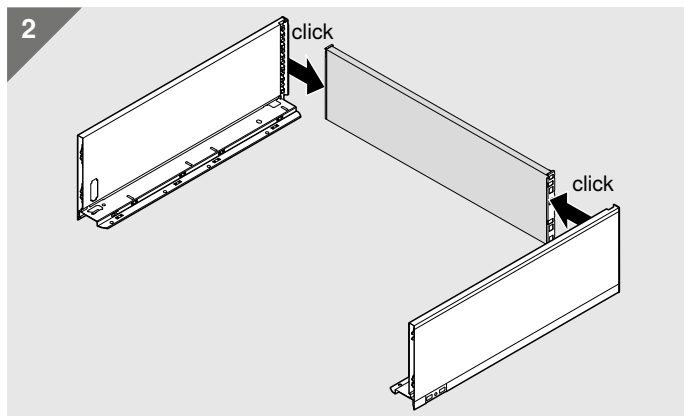
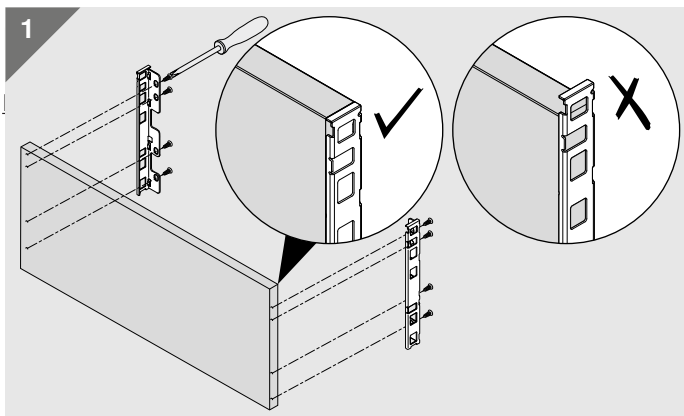

VANITY DRAWER ADJUSTMENT

BLUM

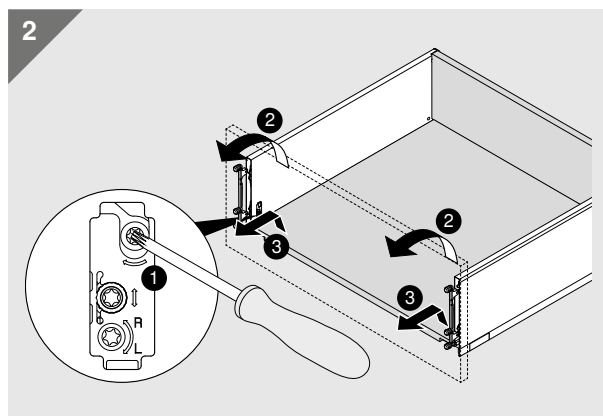
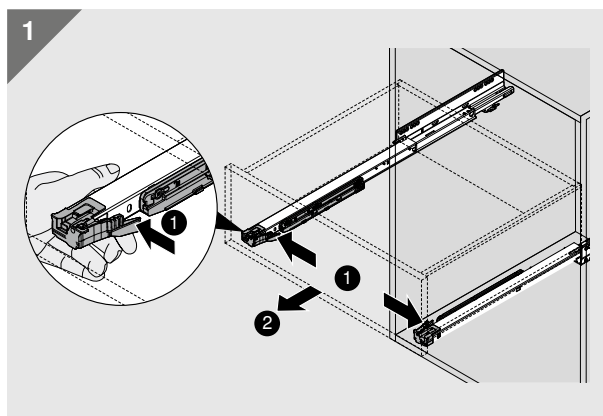
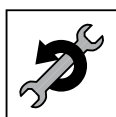
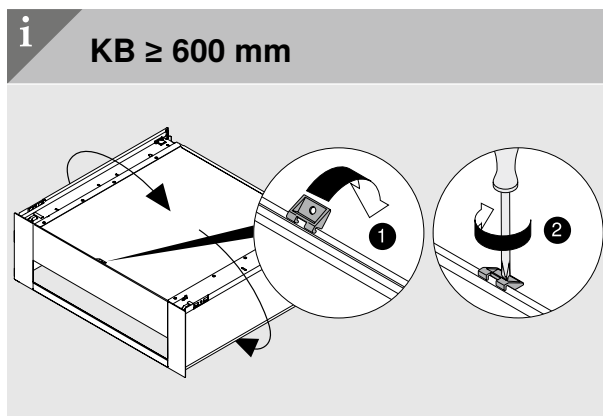
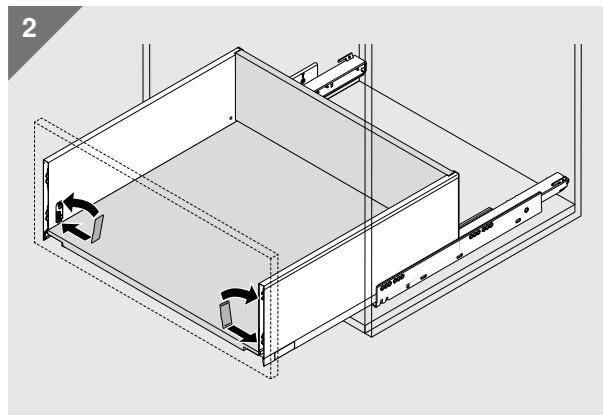
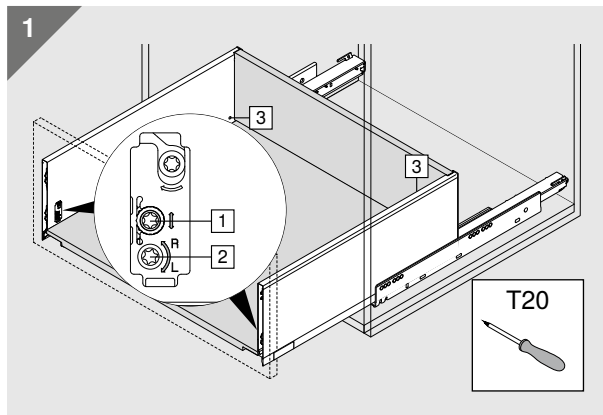
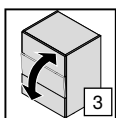
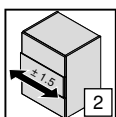
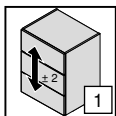

robertson® trade

Robertson Trade has an extensive range of spare parts for all Robertson tapware and toilets, and also stock a wide range of Branded products including PEX, Geberit, WDI, Kerox, Neoperl & Universal parts to help assist the trade in their everyday requirements. If parts need to be replaced due to wear and tear, we recommend using a qualified plumber as any damage caused may void the warranty.

View detailed specifications online at **ROBERTSONTRADE.CO.NZ** or visit our Trade Centre at 42 Vestey Drive, Mt Wellington, Auckland. Open Monday - Friday 8.30am - 5pm Saturday 9am - 1pm Closed Sunday

robertson®
BATHWARE
— SINCE 1987 —

PH: +64 (0)9 573 0490
FAX: +64 (0)9 573 0495
EMAIL: sales@robertson.co.nz

ROBERTSON.CO.NZ

AUCKLAND

25 Vestey Drive, Mt Wellington,
Auckland 1060

Open Monday - Friday 8am - 4.30pm
Saturday 9am - 1pm Closed Sunday

WELLINGTON

23 Marion St, Te Aro,
Wellington 6011

Open Monday - Friday 8.30am - 5pm
Closed Saturday and Sunday

CHRISTCHURCH

37 Mandeville St, Riccarton,
Christchurch 8011

Open Monday - Friday 9am - 4pm
Saturday and Sunday 10am - 2pm



It's all online...

The NEW mobile friendly Robertson website is better than ever with improved usability, new navigation, more functionality and a new world of inspiration just one touch away!

ROBERTSON.CO.NZ